

DESCRIPTION

LS-182SP is a version of LS-182SE, designed to work with Panasonic A or S series motors. For all standard features and parameters please refer to LS-182SE manual.

ORDERING GUIDE

PART NUMBER	MODEL	DESCRIPTION
912182051	LS-182SP-1210	AC Intelligent Servo Drive; 12A/90V
912182052	LS-182SP-2010	AC Intelligent Servo Drive; 20A/90V
912182053	LS-182SP-1220	AC Intelligent Servo Drive; 12A/180V
230601007	LS-182-CN	Mating connector kit for LS-182
230601017	PAN-AS-CN	Mating connector kit for Panasonic A and S series motors

CONNECTORS AND PINOUT

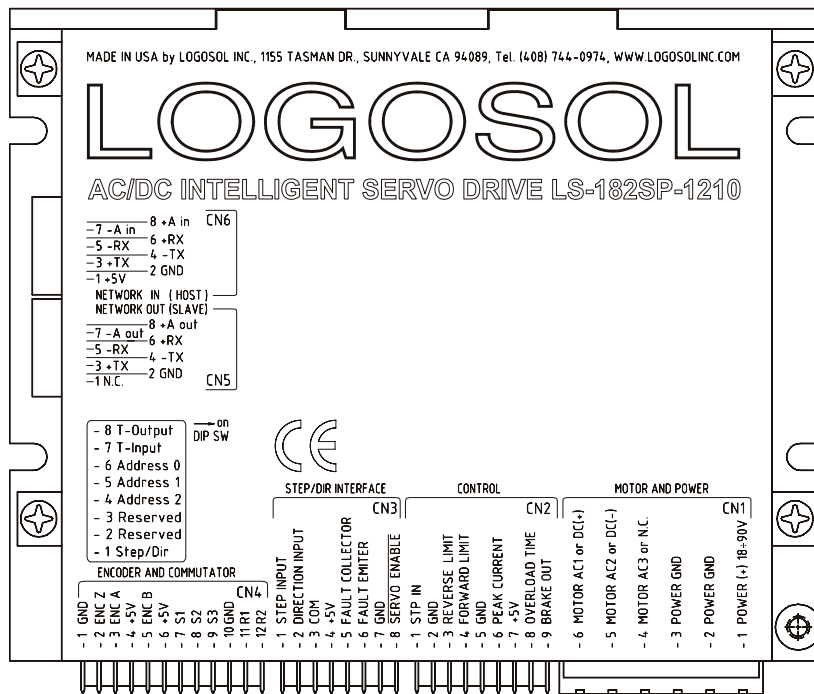

DIP SW – DIP SWITCH

SW	SIGNAL	DESCRIPTION
1	Step/Dir	OFF=Network mode (default) ON=Step/Direction mode
2	Reserved	Reserved. Must be ON
3	Reserved	Reserved. Must be ON
4	Address 2	Address select switch 2
5	Address 1	Address select switch 1
6	Address 0	Address select switch 0
7	T-Input	Transmit line terminator
8	T-Output	Receive line terminator

CN1 – POWER AND MOTOR CONNECTOR

PIN	SIGNAL	DESCRIPTION
1	POWER (+)	18 ÷ 90V power supply, positive terminal
2	POWER GND*	Power supply ground
3	POWER GND*	Power supply ground
4	MOTOR W	Output to motor Phase 3
5	MOTOR V	Output to motor Phase 2
6	MOTOR U	Output to motor Phase 1

CN2 – CONTROL

PIN	SIGNAL	DESCRIPTION
1	STP IN	Stop input (disables servo amplifier)
2	GND*	Signal ground
3	REVERSE LIMIT	Reverse limit input
4	FORWARD LIMIT	Forward limit input
5	GND*	Signal ground
6	PEAK CURRENT	Overcurrent limit
7	+5V**	Signal power supply
8	OVERLOAD TIME	Overcurrent limit timeout
9	BRAKE OUT	Brake output. Open collector 48V/03A

CN3 – STEP/DIR INTERFACE

PIN	SIGNAL	DESCRIPTION
1	STEP INPUT	Step input
2	DIRECTION INPUT	Direction input
3	COM	STEP/DIR interface power supply (+)
4	+5V**	Signal power supply
5	FAULT COLLECTOR	Fault output (+)
6	FAULT EMITTER	Fault output (-)
7	GND*	Signal ground
8	SERVO ENABLE	Servo enable input (active low)

* POWER GND and GND are electrically connected. Drive's case is isolated from drive circuitry and can be grounded externally.

** 200mA Max current for all three outputs combined.

CN4 – ENCODER AND COMMUTATOR

PIN	SIGNAL	DESCRIPTION
1	GND*	Encoder ground
2	ENC +Z***	Encoder phase Z(index)
3	ENC +A	Encoder phase +A
4	+5V**	Encoder power supply
5	ENC +B	Encoder phase +B
6	+5V**	Commutator power supply
7	RX+	Receive commutation data
8	RX-	Receive commutation data
9	ENC -Z***	Encoder phase -Z (index)
10	GND*	Commutator ground
11	ENC -A	Encoder phase -A(+)
12	ENC -B	Encoder phase -B(-)

CN5 – NETWORK OUT (SLAVE)

PIN	SIGNAL	DESCRIPTION
1	N.C.	Not connected
2	GND*	Interface ground
3	+TX	(+) Transmit data
4	-TX	(-) Transmit data
5	-RX	(-) Receive data
6	+RX	(+) Receive data
7	-A out	(-) Address output
8	+A out	(+) Address output

CN6 – NETWORK IN (HOST)

PIN	SIGNAL	DESCRIPTION
1	+5V**	RS-232 adapter power supply
2	GND*	Interface ground
3	+TX	(+) Transmit data
4	-TX	(-) Transmit data
5	-RX	(-) Receive data
6	+RX	(+) Receive data
7	-A in	(-) Address input
8	+A in	(+) Address input

* POWER GND and GND are electrically connected. Drive's case is isolated from drive circuitry and can be grounded externally.

** 200mA Max current for all three outputs combined.

*** The logic level of **Index=bit0 of Auxiliary Status byte** (refer to Status Byte and Auxiliary Status Byte Definitions in LS-182 manual), is changing on every encoder phase C low to high transition.

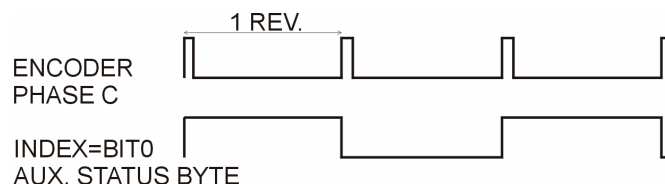

LS-182SP sample application using Panasonic A or S series motor in RS-485 network command mode

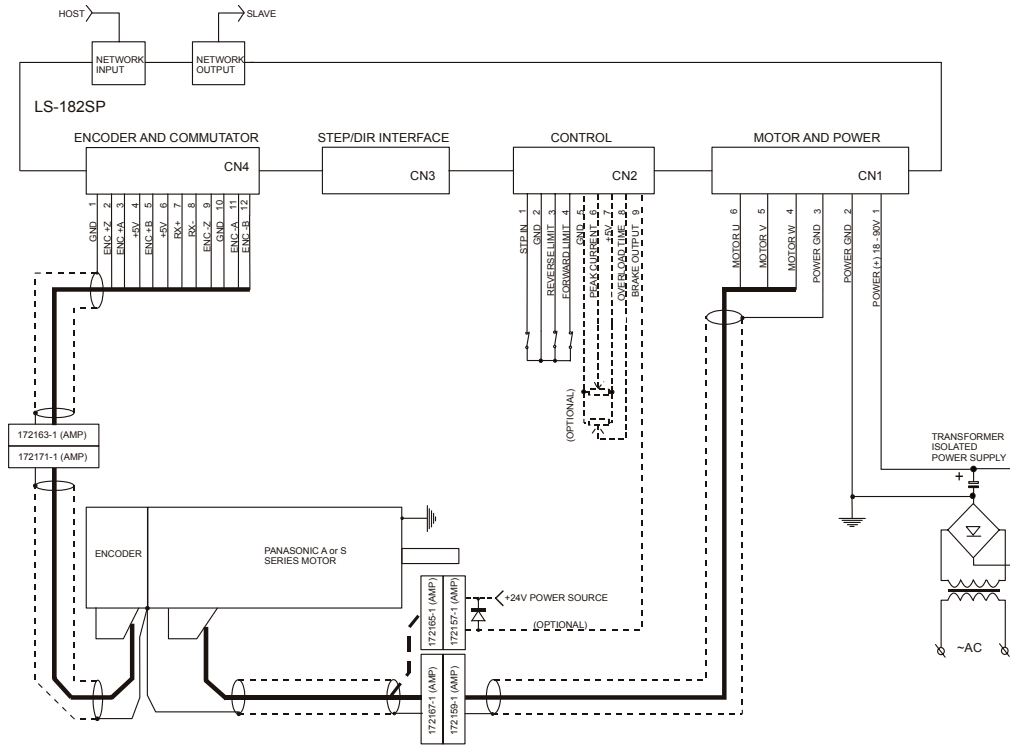

LS-182SP sample application using Panasonic A or S series motor in STEP/DIRECTION mode

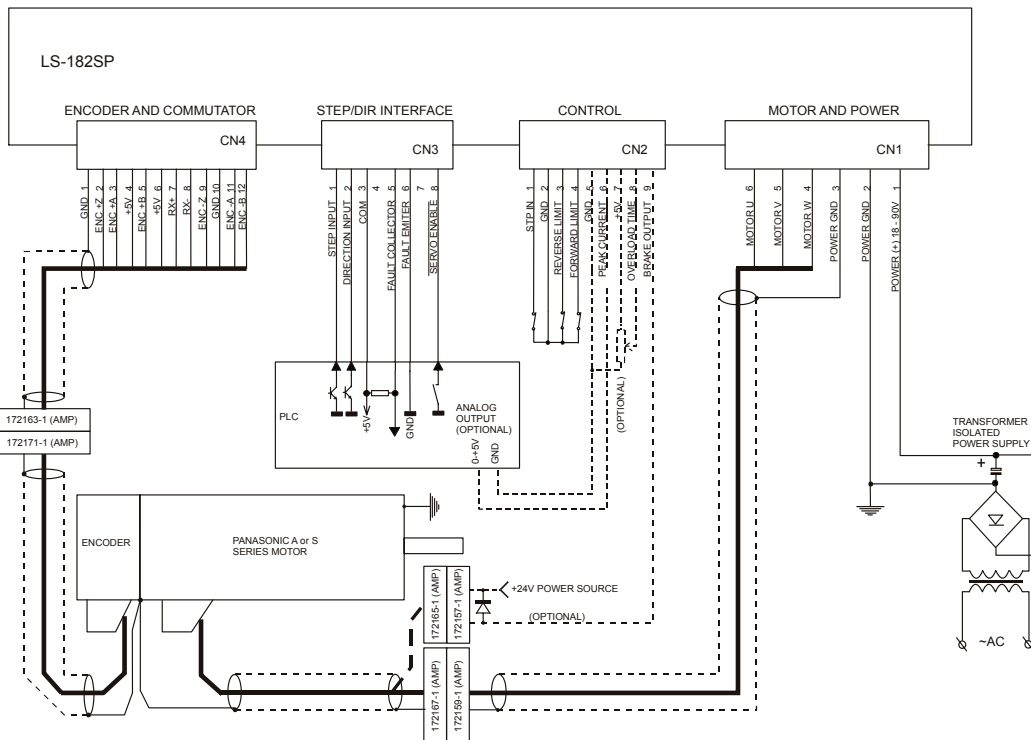

EXTENSION CABLES for PANASONIC A or S-series motors

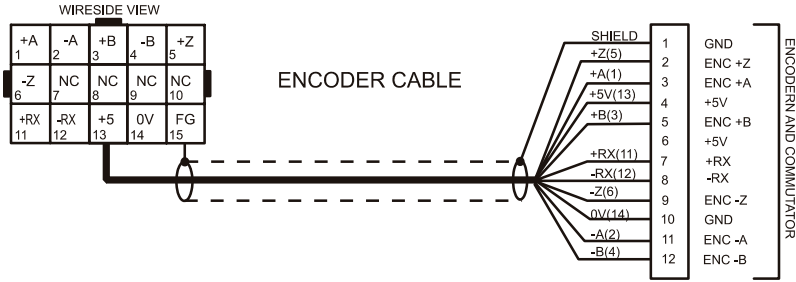

ENCODER CONNECTOR (AMP CAP 172163-1) + 8 pins 170365-1		LS-182SP CONNECTOR (MOLEX 22-01-3127) + 11 pins 08-50-0114	
PIN#	SIGNAL NAME	PIN#	SIGNAL NAME
1	+ A channel output	3	A (+)
2	- A channel output	11	A (-)
3	+ B channel output	5	B (+)
4	- B channel output	12	B (-)
5	+ Z channel output	2	Z (+)
6	- Z channel output	9	Z (-)
11	+RX	7	RX (+)
12	-RX	8	RX (-)
13	+5V	4	+5V
14	0V	10	GND
NA	NA	1	GND (SHIELD)

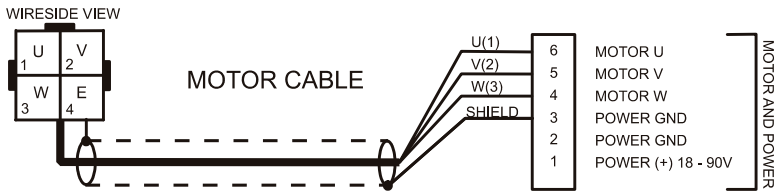

MOTOR CONNECTOR (AMP CAP 172159-1) + 3 pins 170366-1		LS-182SP CONNECTOR (PHOENIX CONTACT MSTB2.5/6-ST-5.08)	
PIN#	SIGNAL NAME	PIN#	SIGNAL NAME
1	U phase	6	MOTOR U
2	V phase	5	MOTOR V
3	W phase	4	MOTOR W
4	E(≡) - SHIELD	3	PPWER GND

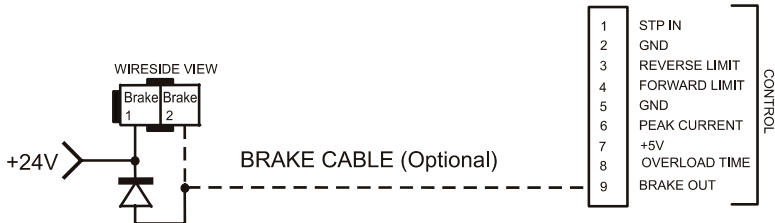

BRAKE (OPTIONAL) AMP CAP 172157-1 2 pins 170366-1		LS-182SP CONNECTOR (MOLEX 22-01-3097) + 1 pin 08-50-0114	
PIN#	SIGNAL NAME	PIN#	SIGNAL NAME
1	Brake	9	Brake/Output1
2	Brake	N.A.	+24V power source

PANASONIC A and S series motors wiring diagram

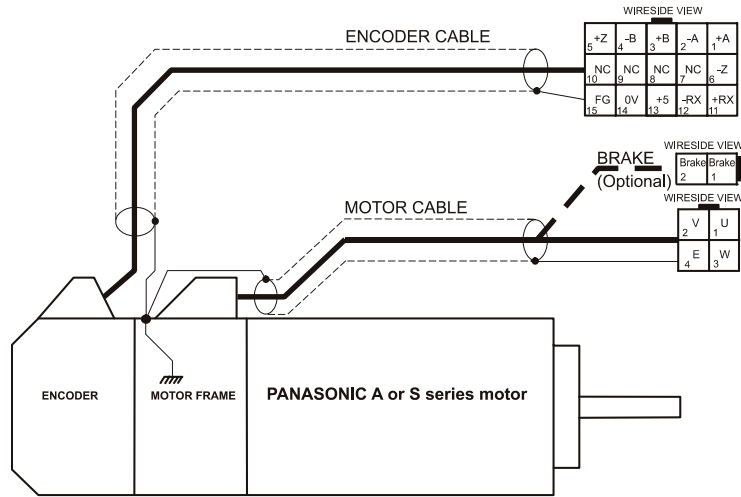

ENCODER CONNECTOR		
PIN#	SIGNAL NAME	WIRE COLOR
1	+ A channel output	Red
2	- A channel output	Pink
3	+ B channel output	Green
4	- B channel output	Blue
5	+ Z channel output	Yellow
6	- Z channel output	Orange
7	NC	NA
8	NC	NA
9	NC	NA
10	NC	NA
11	+RX	Light blue
12	-RX	Purple
13	+5V	White
14	0V	Black
15	FG = motor frame	Black

MOTOR CONNECTOR		
PIN#	SIGNAL NAME	WIRE COLOR
1	U phase	Red
2	V phase	White
3	W phase	Black
4	E = motor frame	Green/yellow

BRAKE CONNECTOR (Optional)		
PIN#	SIGNAL NAME	WIRE COLOR
1	Brake	Yellow
2	Brake	Yellow