

Logosol Network Master Controller LS-980

Doc #712980001 / Rev. 1.2, 05/03/2001

Features

- ❑ 18.432 MHz Rabbit 2000™ CPU
- ❑ 256K FLASH Memory
- ❑ 128K RAM
- ❑ RAM Backup Battery
- ❑ Two Logosol Distributed Control Network (LDCN) ports, hosting of up to 62 network nodes
- ❑ One programming / RS-232 serial port
- ❑ One RS-232 / RS-485 (2 wire) serial port
- ❑ 12VDC to 32VDC single power supply
- ❑ Real-time and multi-tasking capabilities
- ❑ Free Dynamic C® Library supporting Logosol product family for distributed servo, stepper and I/O control
- ❑ Small footprint (5.00" x 3.30" x 0.85")



Description

LS-980 is a powerful, cost-effective, C-programmable CPU module developed especially for hosting of Logosol devices as distributed servo, stepper and I/O control nodes. The programming is accomplished via a standard RS-232 port by using Z-World's Dynamic C® development environment featuring interactive editor, compiler and source level debugger. The high-performance Rabbit 2000™ microprocessor combined with Logosol's servo, stepper and I/O nodes offers a versatile platform for wide range of industrial control applications.

Dynamic C® is an enhanced version of the industry standard C programming language with real-time and multi-tasking capabilities, designed to compile a program with applicable library routines and download the code to a target system. Comprehensive Dynamic C® libraries are available free of charge to facilitate the integration of Logosol controllers with LS-980.

Logosol Network Master Controller LS-980

Doc #712980001 / Rev. 1.2, 05/03/2001

TECHNICAL SPECIFICATIONS rated at 25°C ambient, POWER(+) 12÷32V = 24VDC

POWER SUPPLY VOLTAGE	12÷32 VDC, (10÷40VDC Abs. Max range) Supply current <100 mA at 24VDC
CPU	Rabbit 2000™ – 18.432 MHz
FLASH Memory	256K
RAM	128K
SERIAL INTERFACES	COM A – RS-232 COM B – RS-485 full duplex (4 wire) LDCN compatible COM C – RS-485 full duplex (4 wire) LDCN compatible COM D – RS-232 or RS-485 half duplex (2 wire)
LED Red LED – PD7 controlled	PD7 = input = LOW light intensity PD7 = output set to “1” = light OFF PD7 = output set to “0” = HIGH light intensity
RAM BACKUP BATTERY	3V - CR2032
THERMAL REQUIREMENTS Storage temperature range Operating temperature range	–30 to +85 °C 0 to 45 °C
MECHANICAL Size Weight	5.00”x3.30”x0.85” 0.55lib. (250gr.)
MATING CONNECTORS CN1 – POWER CN2 – COM A CN3 – COM D CN4 – COM C (LDCN 2) CN5 – COM B (LDCN 1)	Magnum EM2565-02-VL or Phoenix MSTB 2.5/2-ST-5.08 D-sub 9pin / female D-sub 9pin / female 8 pin RJ-45 8 pin RJ-45

Logosol Network Master Controller LS-980

Doc #712980001 / Rev. 1.2, 05/03/2001

DIMENSIONAL DRAWING

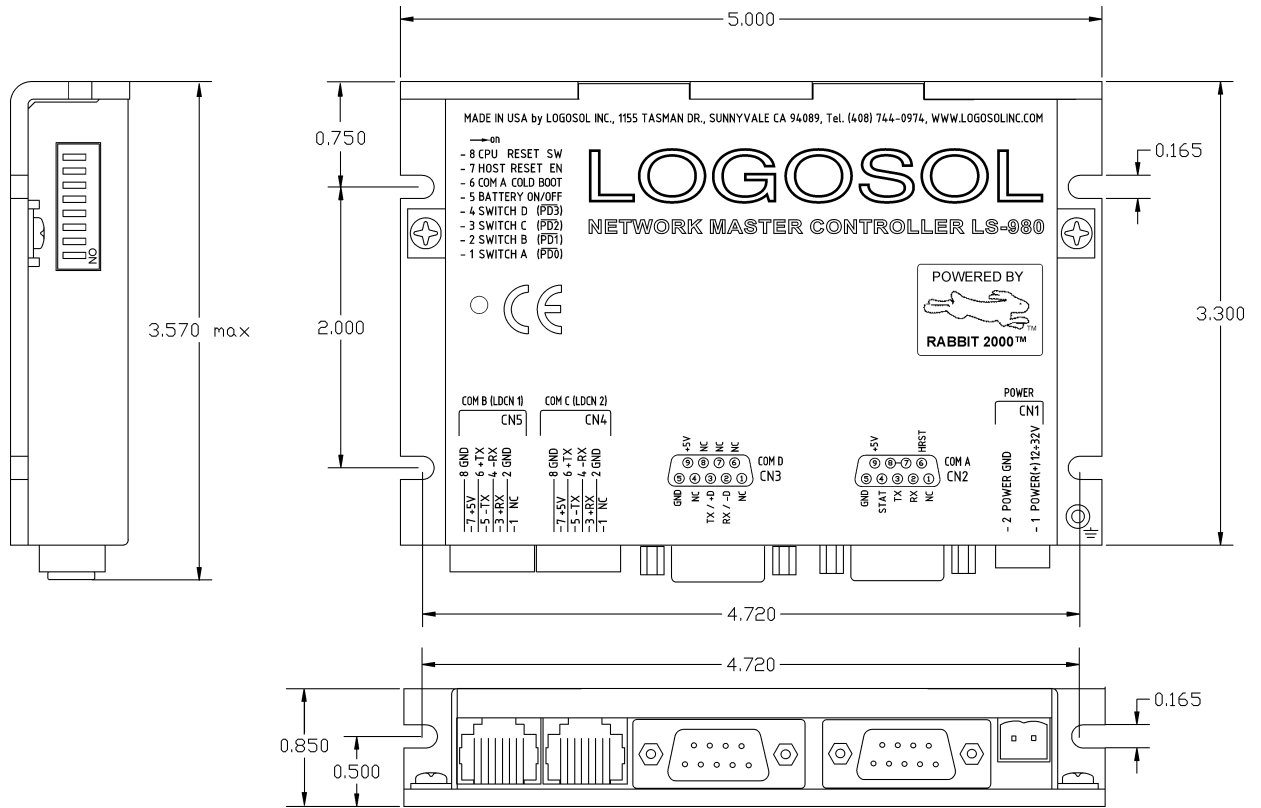

CONNECTOR LAYOUT

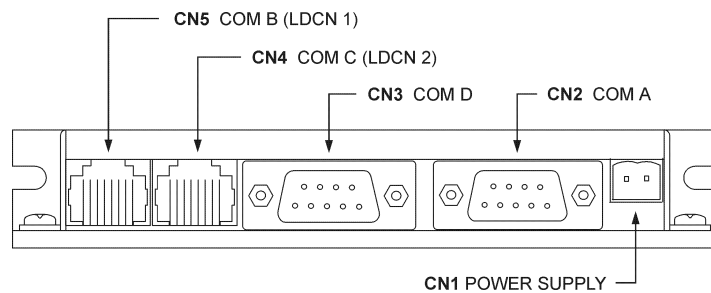

ORDERING GUIDE

PART NUMBER	MODEL	DESCRIPTION
912980001	LS-980	Network master controller, Rabbit 2000™ CPU, 18.432MHz, 128K RAM, 256K FLASH
324010036	EM2562-02-VL	Magnum EM2565-02-VL

Logosol Network Master Controller LS-980

Doc #712980001 / Rev. 1.2, 05/03/2001

CONNECTORS AND PINOUT

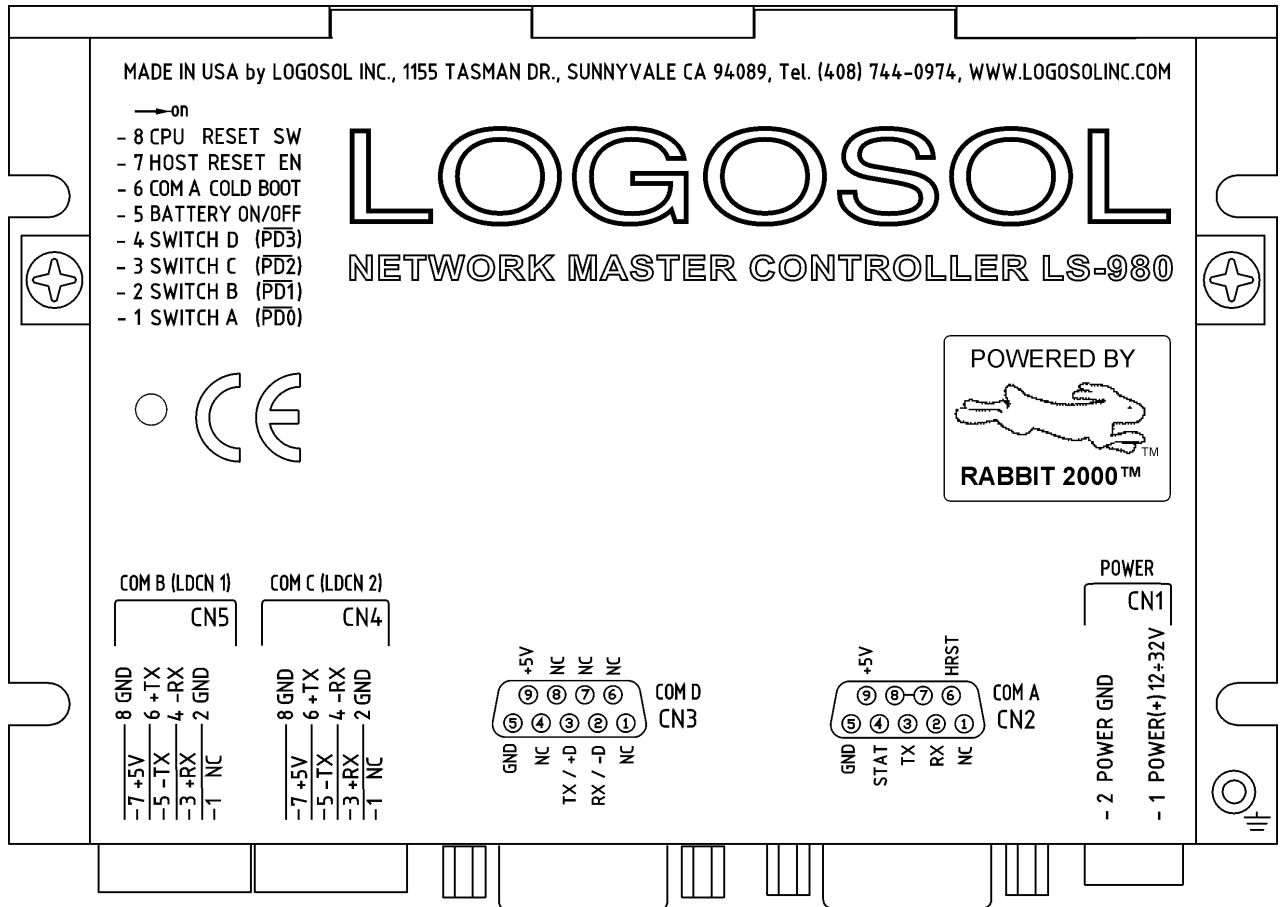

Logosol Network Master Controller LS-980

Doc #712980001 / Rev. 1.2, 05/03/2001

DIP SWITCHES

SW	FUNCTION	DESCRIPTION
1	SWITCH A (/PD0)	Configuration switch connected to PD0 (ON = logic "0")
2	SWITCH B (/PD1)	Configuration switch connected to PD1 (ON = logic "0")
3	SWITCH C (/PD2)	Configuration switch connected to PD2 (ON = logic "0")
4	SWITCH D (/PD3)	Configuration switch connected to PD3 (ON = logic "0")
5	BATTERY ON/OFF	RAM Backup battery ON/OFF
6	COM A COLD BOOT	ON = COM A COLD BOOT ENABLED
7	HOST RESET EN	ON = HOST RESET ENABLED
8	CPU RESET SW	ON = CPU RESET

CN1 – POWER

PIN	SIGNAL	DESCRIPTION
1	POWER (+) 12÷32V	12÷32V power supply, positive terminal
2	POWER GND*	Power supply ground

CN2 – COM A

PIN	SIGNAL	DESCRIPTION
1	N.C.	Not connected
2	RX	Receive data
3	TX	Transmit data
4	STAT	STATUS output from Rabbit 2000™ CPU (used by software development tools)
5	GND*	Interface ground
6	HRST	HOST RESET input (used by software development tools) Enabled by HOST RESET EN switch
7	Connected to pin 8	
8	Connected to pin 7	
9	+5V**	+5V Power output

CN3 – COM D

PIN	SIGNAL	DESCRIPTION
1	N.C.	Not connected
2	RX /-D	RS-232 mode: Receive data RS-485 mode: (-) Data terminal
3	TX /+D	RS-232 mode: Transmit data RS-485 mode: (+) Data terminal
4	N.C.	Not connected
5	GND*	Interface ground
6	N.C.	Not connected
7	N.C.	Not connected
8	N.C.	Not connected
9	+5V**	+5V Power output

Logosol Network Master Controller LS-980

Doc #712980001 / Rev. 1.2, 05/03/2001

CN4 – COM C (LDCN 2)

PIN	SIGNAL	DESCRIPTION
1	N.C.	Not Connected
2	GND*	Interface ground
3	+RX	(+) Receive data
4	-RX	(-) Receive data
5	-TX	(-) Transmit data
6	+TX	(+) Transmit data
7	+5V**	+5V Power output
8	GND*	Interface ground

CN5 – COM B (LDCN 1)

PIN	SIGNAL	DESCRIPTION
1	N.C.	Not Connected
2	GND*	Interface ground
3	+RX	(+) Receive data
4	-RX	(-) Receive data
5	-TX	(-) Transmit data
6	+TX	(+) Transmit data
7	+5V**	+5V Power output
8	GND*	Interface ground

* POWER GND and GND are electrically connected. Drive's case is isolated from the controller circuitry and can be grounded externally.

** 250mA MAX for all outputs combined.

Logosol Network Master Controller LS-980

Doc #712980001 / Rev. 1.2, 05/03/2001

LS-980 ARCHITECTURE OVERVIEW

- CPU - Rabbit 2000™
- CPU clock – 18.432 MHz
- 256K FLASH memory
- 128K SRAM with battery backup
- Two full-duplex (4 wire) RS-485 port for hosting of up to 62 LDCN nodes
- One RS-232 for software development and general purpose applications
- One configurable RS-232 or RS-485 (2 wire) serial port
- LED indicator with two intensity levels

LS-980 Functional Diagram

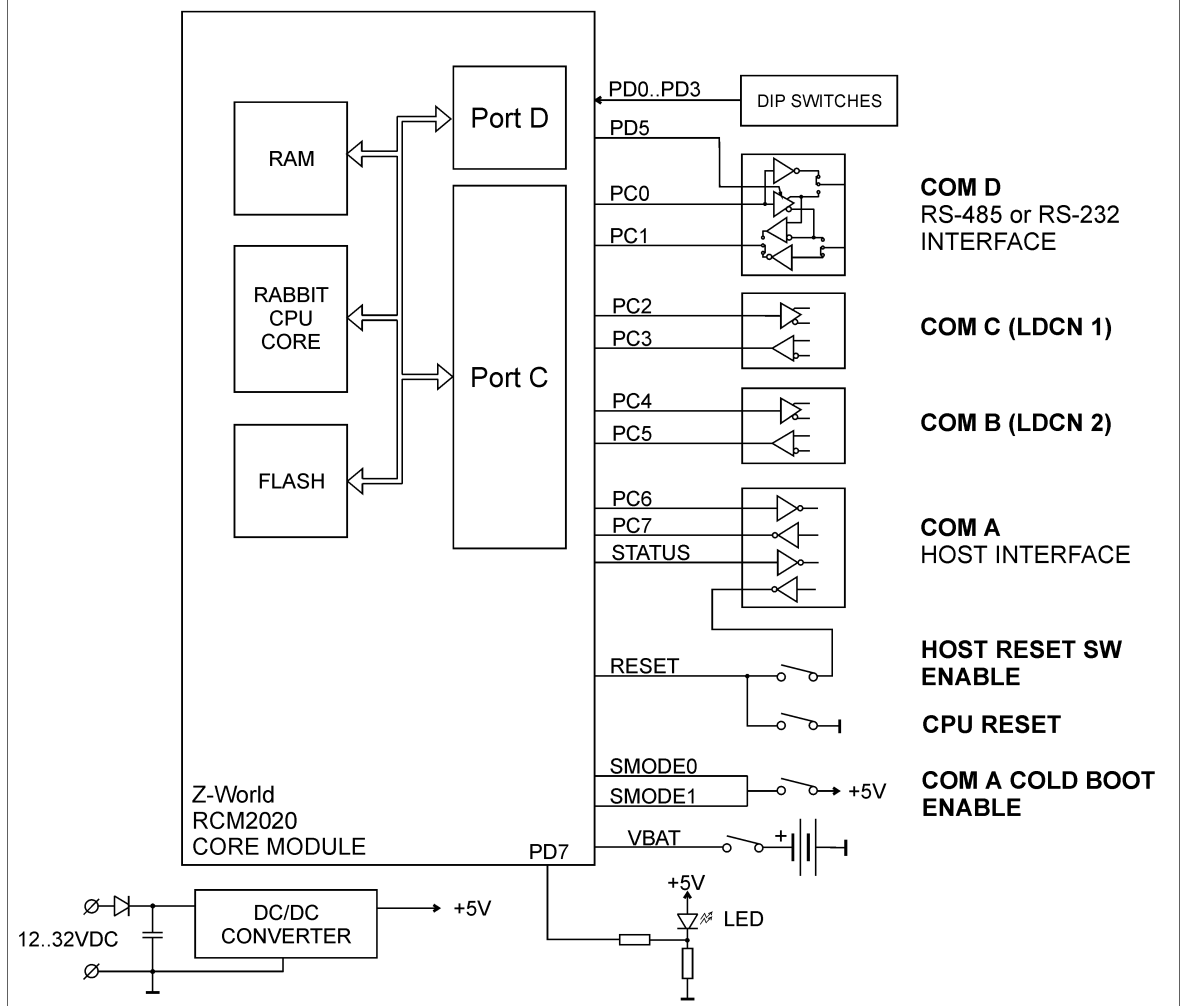

SERIAL INTERFACE (COM A)

- COM A corresponds to Rabbit 2000™ Serial port A.
- COM A schematics:

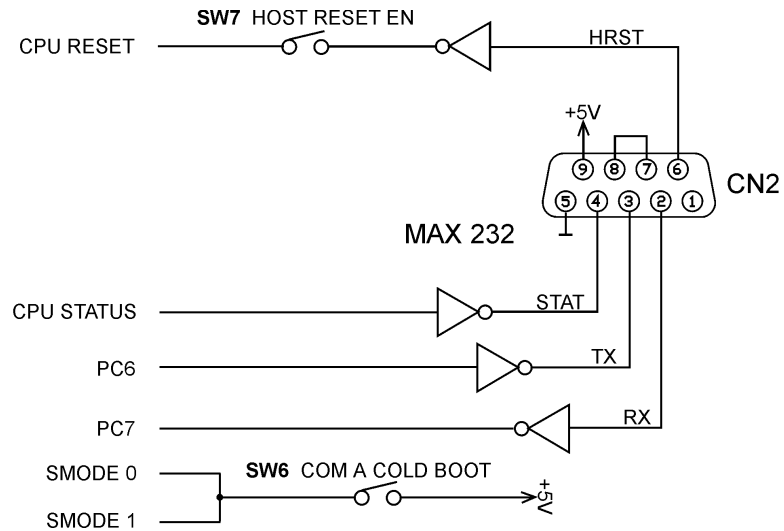

- SOFTWARE DEVELOPMENT mode:
SW 6 = ON
SW 7 = ON
In this mode, LS-980 can be controlled by Z-World development tools.
For more information, see the related documents at <http://www.zworld.com> and <http://www.rabbitsemiconductor.com>.
- RS-232 interface mode:
SW 6 = OFF
SW 7 = OFF
- Typical LS-980 to PC interfacing:

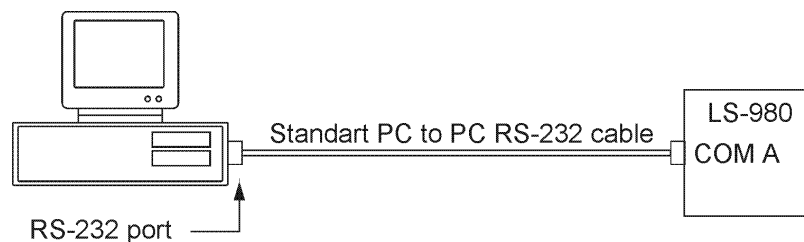

Logosol Network Master Controller LS-980

Doc #712980001 / Rev. 1.2, 05/03/2001

SERIAL INTERFACE COM B (LDCN 1) and COM C (LDCN 2)

- COM B corresponds to Rabbit 2000™ Serial port B.
- COM C corresponds to Rabbit 2000™ Serial port C.
- Interface schematics:

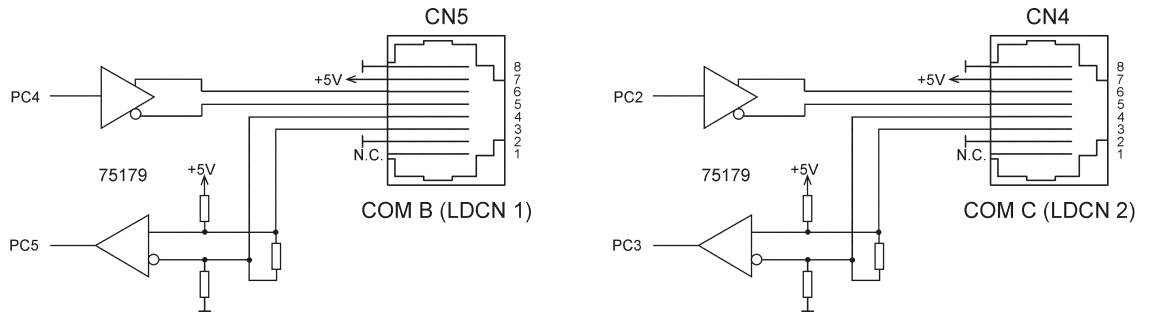

- LDCN 1 and LDCN 2 are especially designed for interfacing with Logosol Distributed Control Network, hosting up to 31 distributed servo, stepper, I/O and other devices per network.
- Typical LDCN application schematics:

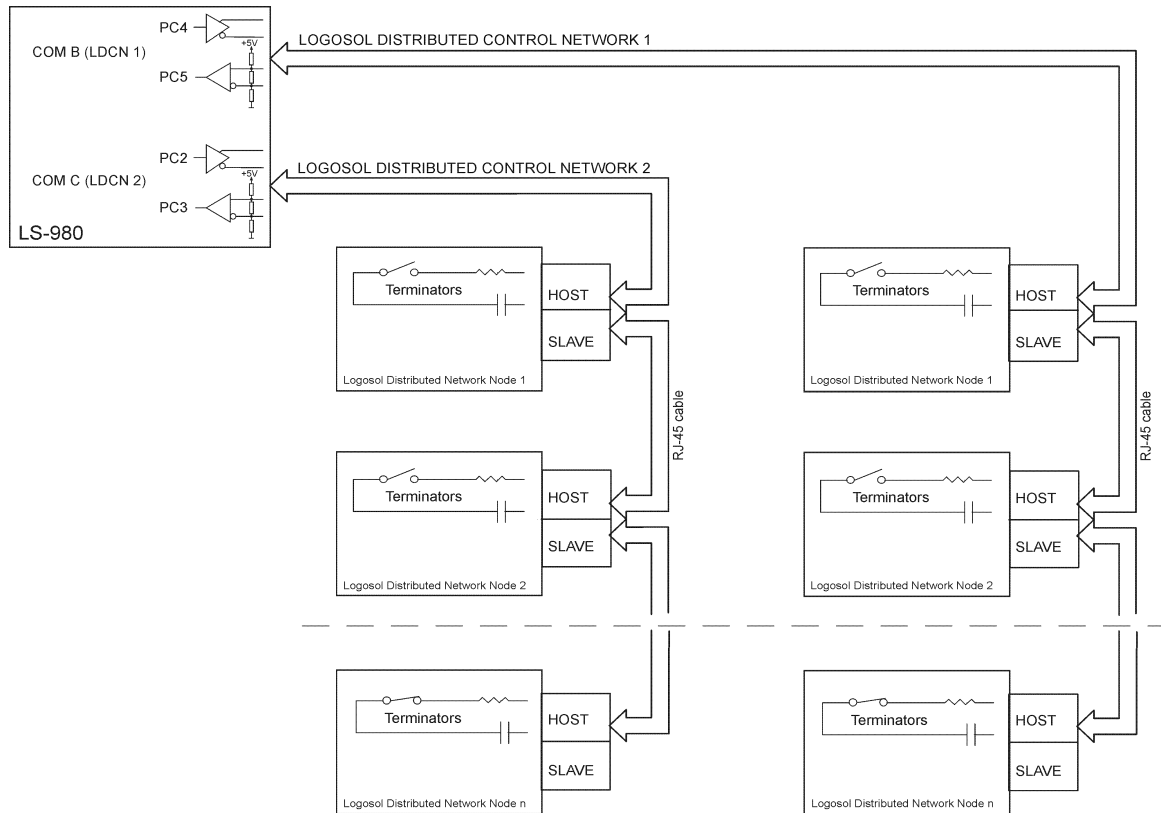

For a full description of LDCN, refer to the manuals and software library, available for download at <http://www.logosolinc.com>.

Logosol Network Master Controller LS-980

Doc #712980001 / Rev. 1.2, 05/03/2001

SERIAL INTERFACE (COM D)

- COM D corresponds to Rabbit 2000™ Serial port D.
- RS-232 mode:

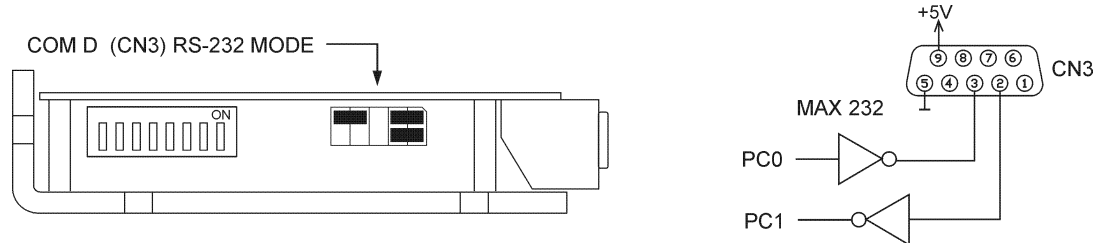

- RS-485 mode:

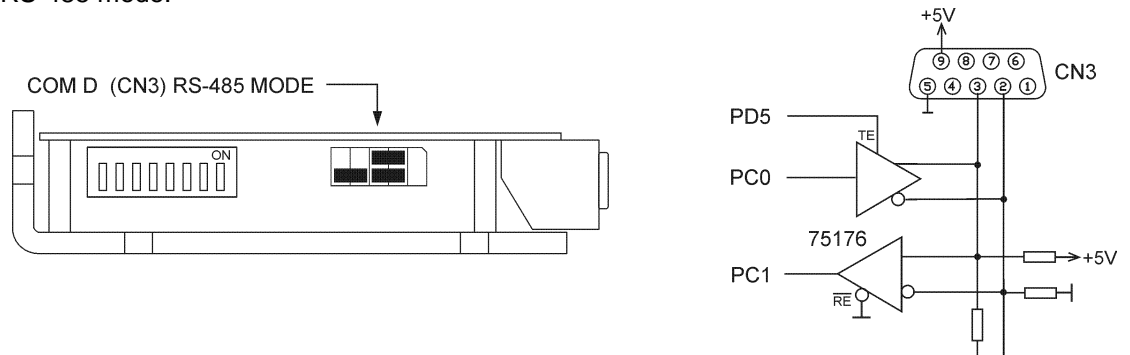

To control the direction PD5 should be programmed as a standard output.
 PD5 = 1 – transmit mode
 PD5 = 0 – receive mode

LED

- LED intensity can be controlled by Rabbit 2000™ Parallel port D bit 7 (PD7).
- LED control schematics:

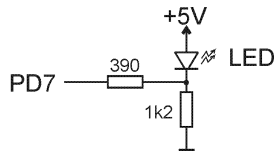

- LED intensity table:

PD7 MODE	STATE	LED INTENSITY
INPUT	X	LOW
OPEN-DRAIN OUTPUT	1	LOW
OPEN-DRAIN OUTPUT	0	HIGH
STANDARD OUTPUT	1	NONE
STANDARD OUTPUT	0	HIGH

The LED intensity control is available for the user software.

DIP SWITCHES

- SWITCH A (SW 1) to SWITCH D (SW 4) are corresponding to Rabbit 2000™ Parallel port D (PD0 ÷ PD3) respectively.
- PD0 to PD3 must be programmed as inputs.
CAUTION! DO NOT PROGRAM PD0 TO PD3 AS OUTPUTS. THIS MAY DAMAGE THE CPU.
- Configuration switches schematics:

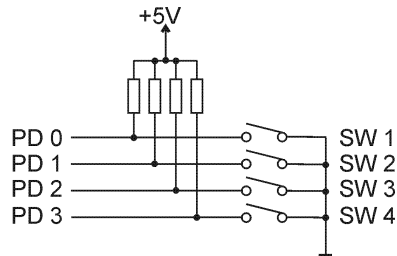

Configuration switches are available for using with user software.

- SW 5 (BATTERY ON/OFF) switch turns on and off RAM backup battery.
SW 5 = ON – RAM keeps the information during power off.
SW 5 = OFF – The information in RAM is destroyed during power off.
- SW 6 (COM A COLD BOOT) switch – see Serial interface COM A
- SW 7 (HOST RESET EN) switch – see Serial interface COM A
- SW 8 (CPU RESET SW) switch corresponds to Rabbit 2000™ CPU master reset.
SW 8 = ON – Rabbit 2000™ CPU in reset condition.
SW 8 = OFF – Rabbit 2000™ CPU is running.

Logosol Network Master Controller LS-980

Doc #712980001 / Rev. 1.2, 05/03/2001

RABBIT 2000 PORTS INITIALIZATION

PORT A

	INITIALIZED AFTER RESET		REMARKS
	DIRECTION	DATA	
PA7	Output	0	Reserved
PA6	Output	0	Reserved
PA5	Output	0	Reserved
PA4	Output	0	Reserved
PA3	Output	0	Reserved
PA2	Output	0	Reserved
PA1	Output	0	Reserved
PA0	Output	0	Reserved

PORT B

	INITIALIZED AFTER RESET		REMARKS
	DIRECTION	DATA	
PB7	Output	0	Reserved
PB6	Output	0	Reserved
PB5	Input	none	Identification – read as logic “0”
PB4	Input	none	Identification – read as logic “1”
PB3	Input	none	Identification – read as logic “1”
PB2	Input	none	Identification – read as logic “1”
PB1	Input	none	Read as logic “1”
PB0	Input	none	Read as logic “1”

PORT C

	INITIALIZED AFTER RESET		REMARKS
	DIRECTION	DATA	
PC7	Input	none	Serial Port A RXD
PC6	Output	none	Serial Port A TXD
PC5	Input	none	Serial Port B RXD
PC4	Output	none	Serial Port B TXD
PC3	Input	none	Serial Port C RXD
PC2	Output	none	Serial Port C TXD
PC1	Input	none	Serial Port D RXD
PC0	Output	none	Serial Port D TXD

PORT D

	INITIALIZED AFTER RESET		REMARKS
	DIRECTION	DATA	
PD7	O.D. Output	1	LED intensity control
PD6	Output	0	Reserved
PD5	Output	0	Serial port D RS-485 mode transmit enable
PD4	Output	0	Reserved
PD3	Input	none	SWITCH D
PD2	Input	none	SWITCH C
PD1	Input	none	SWITCH B
PD0	Input	none	SWITCH A

PORT E

	INITIALIZED AFTER RESET		REMARKS
	DIRECTION	DATA	
PE7	Output	0	Reserved
PE6	Output	0	Reserved
PE5	Output	0	Reserved
PE4	Output	0	Reserved
PE3	Output	0	Reserved
PE2	Output	0	Reserved
PE1	Output	0	Reserved
PE0	Output	0	Reserved